

Manufacturing: Milling Equipment List

- '08 Toyota BM1020 with Fanuc 18i control, 6000rpm geared spindle, 30 tools ATC, CAT 50 TAPER, 300 PSI CTS, 4th axis, (4 machines)
- '08 Toyota AF1000 with Fanuc 18i control, 12,000 RPM direct Drive, 32 tools ATC, CAT 40 TAPER, 300 PSI CTS, 4th axis, (3 machines)
- '06 HAAS VF-4SS 5 Axis w/TRT-210 HAAS Rotary 50 x 20 x 25 Model #051223RC-1
- '05 HAAS VF-4SS Vertical Machining Center 50 x 20 x 25 Model #051223RC-1
- '04 Gildemeister-Divlieg Vertical Precision Z-Axis Presetting Machine w/Cam Pro Vision and Software--FTD950
- '04 HAAS Vertical Machining Center 4th Axis Rotary Head Model #VF-5B/40XT
- '02 Hitachi Seiki Precision Vertical Machining Center 40" x 20" x 17.7" working envelope
- '01 NTC Vertical Machining Center 19.6" x 13.7" x 13.7" working envelope Model #CMC-NV4S w/Fanuc 21MB Control w/twin 4th Axis rotor heads and indexing pallets
- '00 Hitachi Seiki Precision Vertical Machining Center 40" x 20" x 17.7" working envelope Model #VS-50-40 w/Seicos Sigma 18m Control
- '99 Hitachi Seiki Precision Vertical Machining Center 22"x17.7"x17.7" Envelope '98 Bridgeport Series II Vertical Milling Machine 9" x 42" table 3HP
- '95 Alliant OMV Vertical Milling Machine 10" x 50" table 3HP

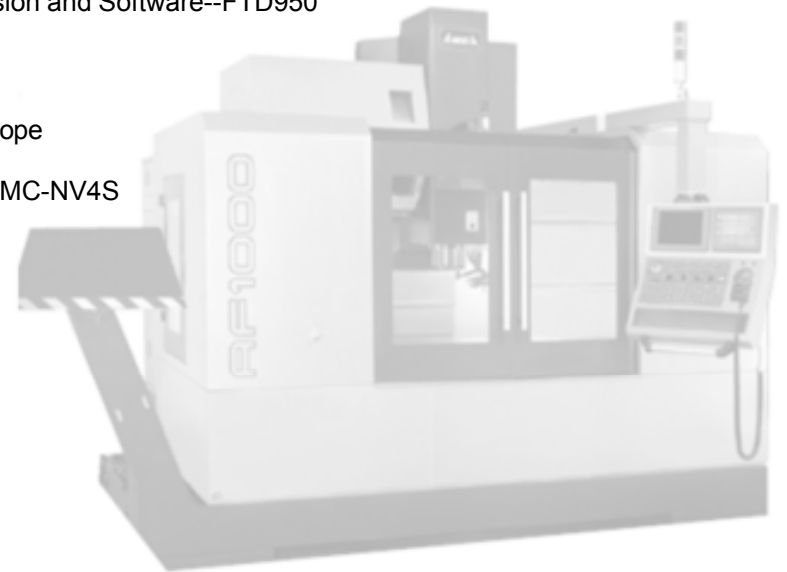

“From Prototype jobs to small & large Production Volumes”

Manufacturing:

CNC Turning Equipment List

- '07 HAAS SL-30 Turning Center, "10" Chuck, 3400 RPM, 30 HP with 880 MP-E 12-foot bar feeder. Bar sizes from .300 to 3.125. Holds 6 bars.
- '05 HAAS SL-40 CNC Turning Center, 7.06 through hole in spindle, 18" Hydraulic 3-saw chuck, 1,400 RPM, 51" between centers
- '03 Mori Seiki SL204 CNC Turning Center 10" x 20" w/live tooling
- '02 Hitachi-Seiki HiTech CNC Turning Center 13.5" x 44.0" TF25
- '01 Mori Seiki CNC Turning Center 10" x 20" Model #SL-253BSMC/500
- '97 Hitachi-Seiki HiTech CNC Turning Center 10" x 24" Model #HT23J
- '97 Hitachi-Seiki HiTech Turn 20SIII 8" 3-jaw chuck 10 x 24
- '95 Clausing/Colchester Lathe Model #8033VS 15" x 50" 10HP
- '95 Clausing/Colchester Lathe Model #8030VS 15" x 25" 10HP w/Pratt-Burnerd chuck and Acu-Rite TurnMate readout
- '95 Sherline Precision Miniature Lathe 3.5" x 18"

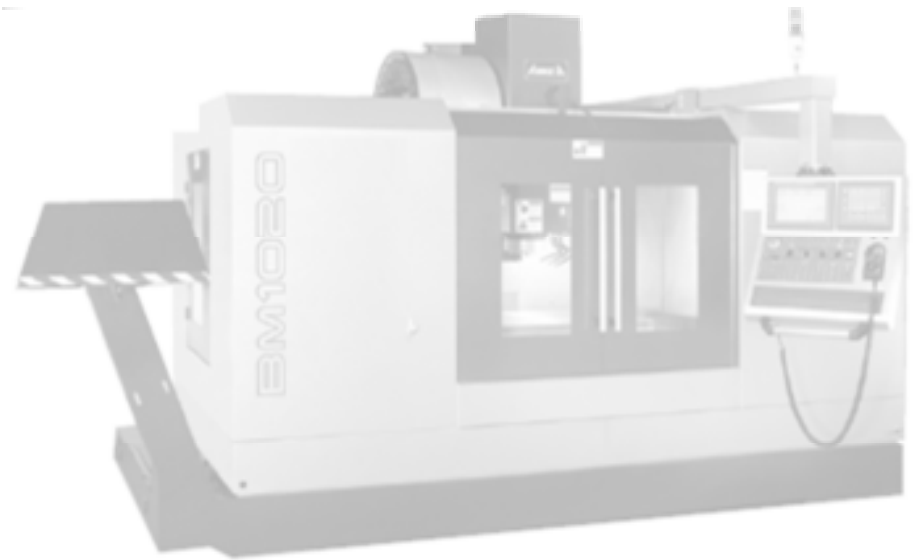

FTS has the skilled manpower & equipment to get the job done, at the right price!

Manufacturing:

Grinding Equipment List

- '05 Jones & Shipman Ultramat 1000 CNC Easy Grind OD Grinder, capacity 12" diameter x 40" long w/gaging, can grind ODs to .0001 plus or minus .00005
- '00 Clausing CSG1640ASDX Automatic Wet Grinder w/ 16" x 40" work area.
- '97 SharpPlus OD618A Automatic Cylindrical Grinder w/ID Attachment and 6" x 18" work area, DRO Readout .0001
- '97 Sharp SP616 Surface Grinder w/6" x 16" work area and Acu-Rite Qwikcount DRO readout .0001
- '96 Kent Surface Grinder w/ 8" x 18" work area and electro-magnetic chuck
- '88 Two Parker Majestic Surface Grinders w/6" x 18" work area and Acu-Rite Qwikcount DRO readout .0001 (2)
- Parker-Majestic Type A Internal Grinder w/10" x 24" work area and 3, 4, and magnetic chucks with extra spindles and accessories
- Moore Jig Grinder Model #3 w/Sony digital readout .0001
- Elgin-30 Rotary Blanchard Surface Grinder w/30" table
- Norton OD Grinder w/6" x 30" work area
- Heald ID Grinder Model 273A w/20" swing



Jig Grinder



Jones & Shipman Ultramat

“Freer Tool & Supply -Your Single Source Solution”

Manufacturing:

Supporting Equipment

- '05 Inducto Heat Statislian II Vertical Scanning Heating Machine (induction heat treat) 200kw, 30khz solid state transistorized inverter, computerized for programming.
- Kalamazoo Semi-Automatic Band saw, Model H460SA 18" Bundle
- Sunnen Precision Honing Machine w/gaging/MBC-1802, power stroke
- Horizontal Band saw 10" x 17" Model MBS-250
- KBC Vertical Band Saw Model BAU-450
- C&M 6.5cu ft. Deburring Machine Model 600DB
- Ford-Smith Pedestal Grinder 8" x 2"
- (3) Dayton Pedestal Grinder 7" x 1" Matco wire feed mig welder, S/N 0920649
- Trinco Sand Blaster Model 36/BP2
- KBC 6" Horizontal Disc and Belt Sander Model 9648
- Dayton 4 ton Press w/punches
- Hydraulic Press 50 Ton
- Hydraulic Bender – bends up to 1" x 4" wide hot rolled steel
- (2) National 12 speed – 1hp drill press
- Birchwood Casey Complete Black Oxide System
- Dayton Dust Collector 36 gallon
- Sullair Rotary Screw Air Compressor 15hp
- Ultra Air Products Refrigerated Air Dryer Model UA-55AC
- Clausing Four Head Gang Drill, 33" x 88" Table w/4 2hp Motors
- Mr. Deburr – Vibrating Tumbler
- Helicoil Insert Installer (production)
- 16" Granite Bench Center
- 36" Granite Bench Center

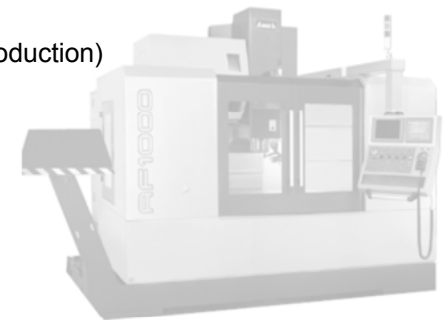

“From Prototype jobs to small & large Production Volumes”

Quality & Inspection:

In-house inspection equipment

- Jones & Lamson Optical Comparator Model Epic 30 w/Quadra-Check 200 (readouts .00005)
- Mitutoyo CMM-Bridge type 45 x 32 x 22 table air ride, air lock, w/Quadra-Check (qc5000)
- Mitutoyo 0 - 24" Precision Heightmaster (3)
- Mitutoyo 0 - 18" Digital Heightmaster (6)
- Omni Gage 5" - 19" (.000050 accuracy)
- Gage Block Sets--Certification available upon request (10)
- .011 - 1.0 Pin Gage Set (5)
- Mitutoyo Profilometer
- Assorted Thread Gages
- 4' x 6' Granite Surface Plate
- Assorted Inspection Equipment
- Wilson Rockwell Hardness Tester
- Sunnen Dial Bore Gages (4)

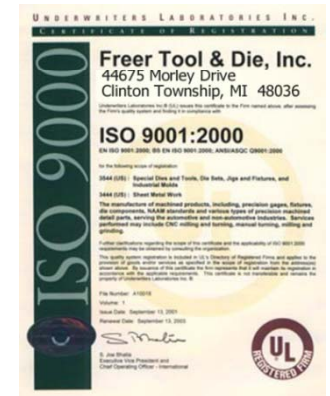
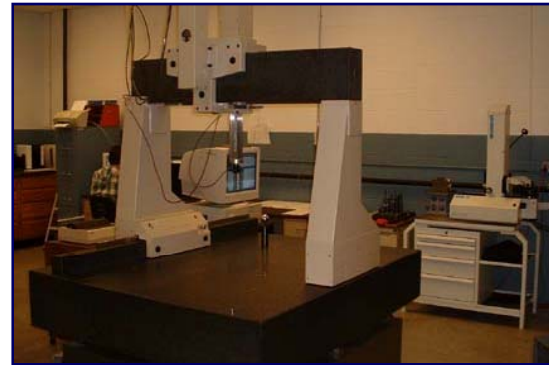

ISO 9001-2000 certified and 17025
compliant by Underwriters Laboratory
since April, 2001

FTS has the skilled manpower & equipment to get the job done, at the right price!